

The High Resolution Spectrograph of TNG: a Status Report

R.G. Gratton, A. Cavazza, R.U. Claudi, M. Rebeschini

Astronomical Observatory of Padova, vicolo dell'Osservatorio 5,
I-35122 Padova, Italy

G. Bonanno, P. Bruno, A. Cali, S. Scuderi, R. Cosentino

Astrophysical Observatory of Catania, Viale A. Doria,6
I-95125 Catania, Italy

S. Desidera

Dipartimento di Astronomia, Università di Padova, vicolo dell'Osservatorio 5,
I-35122 Padova, Italy

ABSTRACT

The high resolution spectrograph of the TNG (SARG) was projected to cover a spectral range from $\lambda=0.37$ up to $0.9 \mu\text{m}$, with resolution ranging from $R=19,000$ up to $R=144,000$. The dispersing element of the spectrograph is an R4 echelle grating in Quasi-Littrow mode; the beam size is 100 mm giving an RS product of $RS=46,000$ at order centre. Both single object and long slit (up to 30 arcsec) observing modes are possible: in the first case cross-dispersion is provided by means of a selection of four gratings; interference filters are used for the long slit mode. A dioptric camera images the cross dispersed spectra onto a mosaic of two 2048×4096 EEV CCDs (pixel size: $13.5 \mu\text{m}$) allowing complete spectral coverage at all resolving power for $\lambda < 0.8 \mu\text{m}$. Confocal image slicers are foreseen for observations at $R \geq 76,000$; an absorbing cell for accurate radial velocities is also considered. SARG will be rigidly fixed to one of the arms of the TNG fork by means of an optical table and a special thermally insulating enclosure (temperature of all spectrograph components will be kept constant at a preset value by a distributed active thermal control system). All functions are motorized in order to allow very stable performances and full remote control. The architecture of SARG controls will be constructed around a VME crate linked to the TNG LAN and the instrument Workstation B by a fiber optic link.

Keywords: Spectrograph, Echelle, Control System

1. THE INSTRUMENT

SARG is a high resolution spectrograph for the Italian Telescopio Nazionale Galileo (TNG, La Palma, Canary Island, Spain). It is a joint effort of the Padova Astronomical Observatory (which has the responsibility of optics, mechanics, and high level software) and Catania Astrophysical Observatory (controls, low level software and detectors). Detailed mechanical design and definition of the optical alignment procedures have been contracted to private firms (Laserpoint, CINEL, SPOT).

SARG is one of the TNG baseline instruments. It is designed to be a general purpose, permanently mounted and remotely operated instrument serving the whole Italian astronomical community, within the TNG standards. Scientific drivers were observation of planets orbiting around stars; asteroseismology; the collection of data on the mechanism of galaxy formation by statistical studies of the absorption lines in QSO spectra and by analysis of the chemical composition of fossil remnants of very early stellar populations; studies on stellar and planetary atmospheres; and the interstellar medium.

The layout of the instrument is shown in Figure 1. The spectrograph is mounted on an optical table rigidly fixed to the fork arm of the telescope within a thermal controlled enclosure (not shown in the figure). The temperature inside the enclosure is kept constant at $(20 \pm 0.5)^\circ\text{C}$ by means of a Distributed Active Thermal Control System (DATCS) which may be controlled by software. The light coming from the Nasmyth focus B is deviated towards the spectrograph at about 2 m below the derotation axis by means of a train of optics mounted on a dedicated position of a slide in the mechanical structure of the TNG Low Dispersion Spectrograph. The SARG preslit optics has also other functions: the field derotation (counter-rotating fused silica Abbe König prism, field 30 arcsec), the Shack-Hartmann active optics system and the guide.

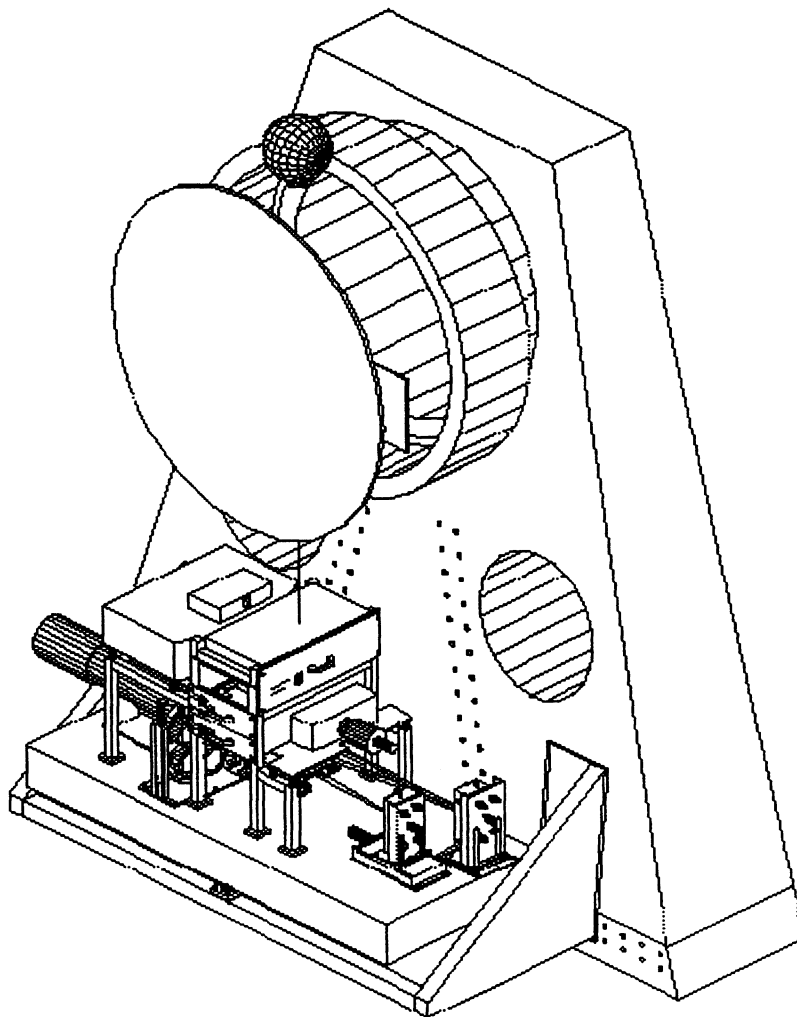

Figure 1: SARG layout

In this way SARG will be a permanently on-line and aligned instrument.

As in various recently built spectrographs the collimator has a Baranne¹ (1972) white pupil design with two off-axis paraboloids. The single blank, 31.6 gr/mm R4 echelle is used in quasi Littrow configuration. At center of each order, the slit width resolution product is $RS=46,000$. Confocal image slicers (Diego² 1994) will be used in order to have a high efficiency even at resolutions of $R \geq 76,000$.

The whole free spectral range is visualized on the camera for wavelengths shorter than 850 nm. Cross dispersion is obtained by means of gratings (there are four gratings available in a five position wheel). SARG has a fully dioptric camera with a focal length of 482.5 mm and a corrected field of 8.5 degrees (radius). The detector is a mosaic of two 2048×4096 (pixel size: $13.5 \mu\text{m}$) thinned, back illuminated EEV CCDs. On this detector, 2 pixels yield a resolution of $R=144,000$ (at field center).

SARG commissioning is currently foreseen at mid 1999. Slightly more than 60% of the required funds have been assigned, allowing to place contracts for about 45% of the instrument (most of the optics, part of the mechanics, some part of the controls, and the integration laboratory). In the subsequent sections we give a description of the status of the project, in particular: in Section 2 the results of the tests of the camera are described; in Section 3 the status of the other optical elements is presented. In Section 4 various aspect of the mechanics are described. The control architecture is described in Section 5, while the SARG laboratory is presented in Section 6. A complete description of the final design of SARG is given in Gratton et al.³ 1996.

2. CAMERA

The SARG camera (see Figure 2) is a dioptric camera made by SESO following our own optical design. The camera focus cannot be adjusted (spectrograph focus is obtained by moving the transfer collimator); however, a set of rings of various thickness allow to adjust back focal distance within a certain range during alignment.



Figure 2 :The dioptric camera of SARG

Design of the camera mechanics grant that no temperature adjustment is required during normal spectrograph operation due to temperature fluctuations within the limits set by the SARG active control system: $(20 \pm 0.5)^\circ\text{C}$.

Specifications of the SARG camera are shown in Table 1.

Focal Length	482.5 mm
Back Focal Distance	4 mm
FoV (diameter)	8.5 degree
EE80 (over the whole field)	$\leq 20.0 \mu\text{m}$
Scale	$83.4 \mu\text{m}/\text{arcsec}$
CCD Format	$2 \times (2048 \times 4096)$
Pixel size	$13.5 \mu\text{m}$

Table 1: Specifications of the SARG Camera

The optical testing was performed at SESO, in order to investigate the camera optical quality (on-axis and off-axis), the focal length, the back focal distance, and the vignetting.

The on-axis image quality was evaluated by exploiting an arc source with a set of interferential filters (with a 4 nm band width) and a $50 \mu\text{m}$ aperture in the focal position of SESO collimator (an off axis paraboloid with a diameter of 230 mm and a focal length of 2000 mm). On the focal plane of the camera there was a CCD (pixel size: $8 \mu\text{m}$) equipped with a microscope objective (magnification $\times 20$). The results (EE80 diameter) are shown in Figure 3 together with the specification values. Note that aperture projected size on the camera focal plane is $12 \mu\text{m}$. The values of EE80 shown in Figure 3 should be deconvolved for this quantity in order to provide the real optical quality of the SARG camera. Note also that these values were obtained without moving the CCD (i.e. with the same back focal distance).

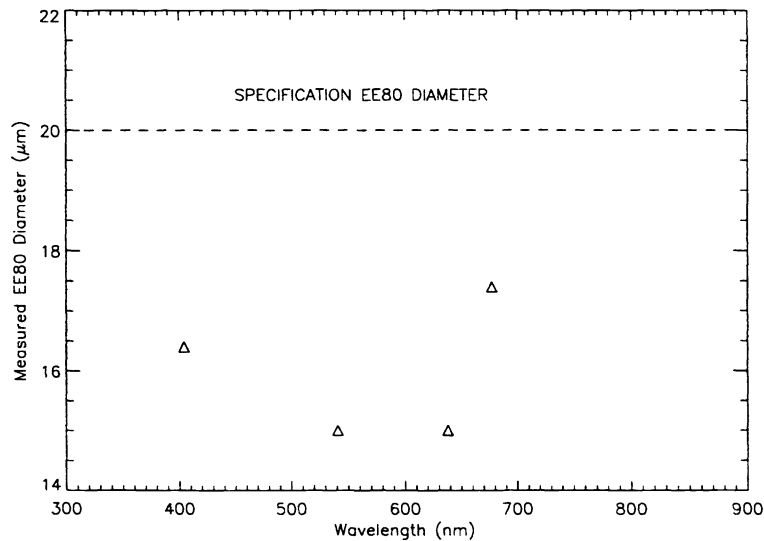

Figure 3: Measured optical quality of the SARG camera

The off-axis quality was tested exploiting a laser source at 633 nm and the same set up (the source used for on-axis measurement cannot be used due to the large lateral color of this spectroscopic camera). Measures were taken at 4.2 degree from the center of the field of view in the two principal axis of the lens. Note that the last surface of the field lens has a cylindrical power on the vertical direction, to compensate for the field curvature of the white-pupil collimator; however, the SESO collimator has no field curvature. The four spot dimensions are between $12 \mu\text{m}$ and $18.6 \mu\text{m}$.

Back focal distance and the focal length were measured exploiting an autocollimator with a source at 520 nm. Back focal distance was checked against the field curvature induced by the cylindrical field lens yielding values of 3.98 mm at the central position and of 3.97 mm at the extremes of the field of view in horizontal direction. In the vertical position the value of 6.31 mm for the back focal distance agree with the field curvature expected with the cylindrical lens.

The focal distance was evaluated from the camera scale obtaining the value $f=485.71$ mm. The scale at the Telescopio Nazionale Galileo will be $82.6 \mu\text{m}/\text{arcsec}$ ($0.163 \text{ arcsec}/\text{pixel}$ with a pixel size of $13.5 \mu\text{m}$), neglecting the anamorphic magnification due to the echelle and the grisms cross dispersers.

3. OTHER OPTICAL COMPONENTS

Contracts for most of the other optical components (Preslit Optics, Collimator Mirrors, Grism Cross Dispersers) have been placed after bidding to european firms (SESO and FISBA Optik). As for the camera, we took responsibility for the optical design, in order to reduce costs. All these elements are in the construction phase, and no major technical problems are foreseen. The most significant concern is about the (highly critical) alignment of the Abbe-König derotating prism. Nearly perfect alignment between the optical and mechanical axis will be obtained by performing the optical alignment with the prism (and its cell) already mounted within the rotating table (see next section).

Funds for the remaining optical components (echelle grating and some minor off-the-shelf components) are already available; contracts will be placed in the next few months. The complete set of SARG optics is expected to be ready within late spring 1998.

4. MECHANICS

Construction drawings of SARG mechanics are ready. Reduced cost, easy maintenance, and thermal behavior were major concerns in instrument design. The feeding unit of the spectrograph is located on the TNG Low Dispersion spectrograph (DOLORES) slide while the other components are all mounted on a commercial optical table rigidly connected to the telescope fork. To make various instrument parts more easily accessible, we mounted all components in the preslit part of the optical path within removable boxes, fixed to a rigid structure realized by means of commercial (Daedal) components, mounted on the optical table. Most of the instrument is within a thermally insulating, 50 mm thick enclosure. Temperature is maintained at 20 ± 0.5 C by a Distributed Active Temperature Control System (DATCS). This is presently under design: tests with an array of MINCO HEATERSTAT sensorless temperature controllers, providing a simple and cheap solution, will be performed in the next months (we hope to present some results at the meeting). If this solution will be adopted, the DATCS will be integrated with a set of temperature sensors controlled by a commercial temperature monitor: this will allow fine tuning of the system during the integration phase, and continuous on-line testing of the temperatures in various location within the spectrograph when SARG will be in operation.

In order to reduce temperature changes and inhomogeneities within the spectrograph, those functions requiring most frequent maintenance and generating heat (dewars requiring filling with liquid N₂; the Peltier cell used to cool the slit viewer detector; the calibration lamps) are located outside the spectrograph enclosure. Suitable optical windows allows beams from the spectrograph, the calibration lamps, and toward the slit viewer to pass through the enclosure; the first one can be tilted, in order to provide fine alignment of the telescope and spectrograph optical axis (the three other degrees of freedom required for this alignment are obtained by acting on the spectrograph supports). Care has been taken in order to provide for a passive compensation of expected disalignment between telescope and spectrograph due to the different thermal expansion coefficients of the used materials.

Finally, all frequently used instrument functions are motorized, so that the instrument insulating enclosure should be open rarely (and only for maintenance). Five of these functions are realized by means of commercial (OWIS) slides and rotating tables. The remaining four functions (optical derotator, filter, slit and grism wheels) are realized by means of a set of annular rotating tables. The original scheme of these tables was prepared by us, and later modified by CINEL who constructed them. Precise rotation of these tables is ensured by precision-ground, steel-hardened worms and gear drives, which provide smooth motion. No backlash is realized by means of a spring plunger pushing the worm against the threaded wheel. The springs act on one of the ball bearings supporting the worm. A pre-loaded, recirculating ball-bearing supports the rotating part of the stages which includes the threaded wheel, the platform where the components to be inserted into the spectrograph optical path are mounted, and two rings (one on each side) used for fixing the platforms to the threaded wheel. The annular rotation stages will be fixed to the spectrograph structure by three L-mountings at 120 degrees. Preliminary tests show that the these annular tables can be positioned with an accuracy

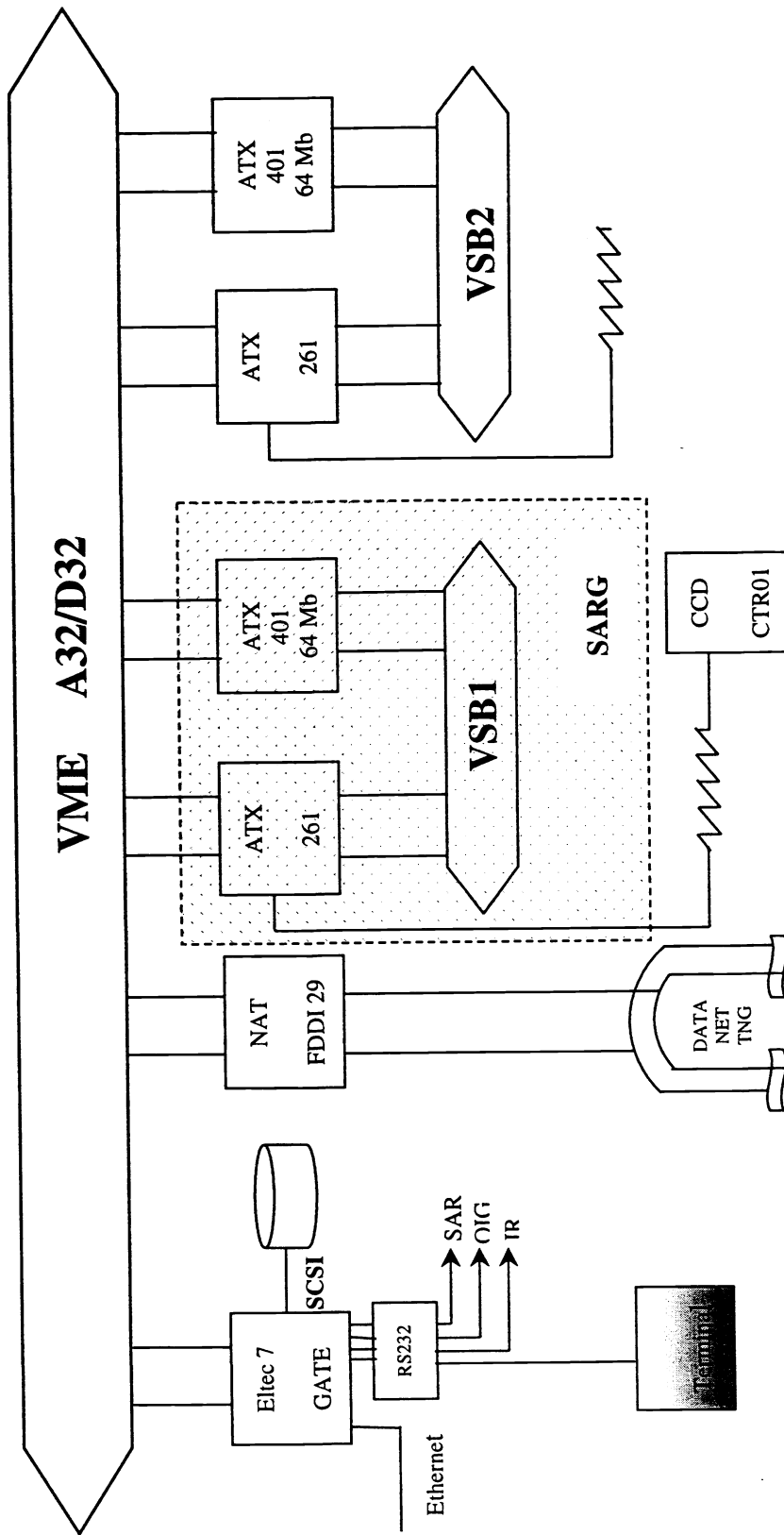

Figure 4: SARG Control Architecture

(repeatability) better than 0.005 degrees; this means that e.g. the slits can be positioned with an accuracy better than $6\ \mu\text{m}$ (which corresponds to about 0.03 arcsec projected on the sky; spectral shifts of <0.2 pixels are then expected when the slit is repositioned).

All motorized functions (including the custom ones) have a servo-controlled DC motor plus an incremental encoder, and are equipped with home switchers allowing the stages to be returned to a reference origin position. All functions can be software controlled by commercial OWIS DC-500 motor controllers.

5. CONTROL ARCHITECTURE

A sketch of the instrument control system architecture is shown in Figure 4. Briefly, the concept of SARG instrument control reflects the future philosophy that will be adopted for all TNG instruments. The real time control of the instrument axis movimentation is made exploiting the TNG Instrument VME crate, while a UNIX Workstation will be employed for the user interface. The TNG Instrument VME has twenty slots. Two slots are used for the CPU. Every TNG instrument uses three slots for an Athenix board (requiring two slots) allowing acquisition from the scientific CCD controllers (through a fiber optic link), and an Athenix memory card. The Athenix board are linked together by an additional VSB bus. One additional slot is occupied by a DAS FDDI board which allows fast communication with the TNG LAN.

Strict compatibility between the TNG instrument Control System and the other TNG Control System (Active Optics, Drivers etc.) is achieved by using GATE software to drive the links between the instrument VME and the other system components, and the same user interface. Futhermore the acquisition systems are based on the standard TNG boards (which also drive the shutters). The only difference between SARG and the other TNG systems are at the low level controllers. SARG uses commercial stand -alone controllers. The use of stand alone systems allows easy set up and debugging, and reliable instrument control.

Communication between the instrument VME and these controllers is realized by means of RS-232 serial links which use standard GATE drivers.

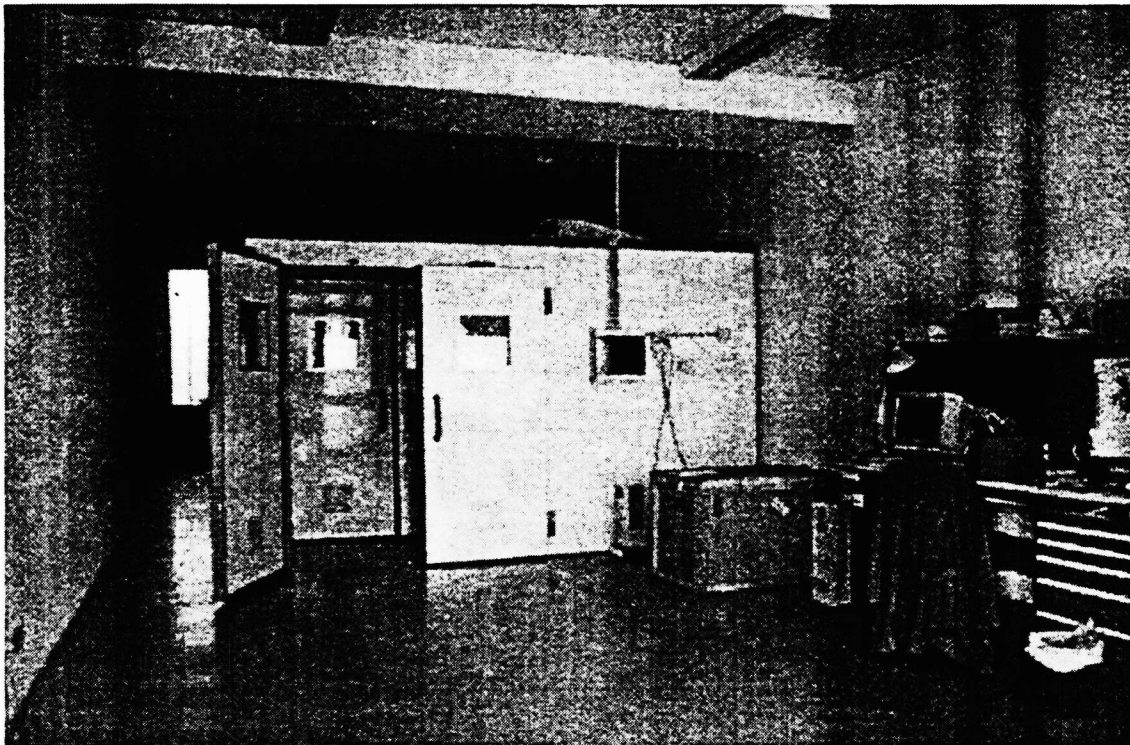

Figure 5: SARG Optical Laboratory

While for most of TNG instruments (located at Nasmyth foci) guiding and active optics functions are provided by TNG Rotator Adaptors, they must be replicated for SARG, since this is located on a position fixed to the TNG arm. In order to ensure real time closure of the guiding loop (avoiding the delays of the TNG LAN) the controller of the SARG Slit Viewer Detector is directly linked to the TNG Active Optics VME, which also controls the Rotator Adaptors cameras. The SARG Slit Viewer Detector thus effectively is the fifth Guiding/Active Optics camera of TNG. The signal commanding parallactic angle reaches the controller of the SARG optical derotator through a dedicated RS-232 serial link from the TNG Driver VME.

6. OPTICAL LABORATORY

SARG will be integrated and aligned (and control software will be tested) in an optical laboratory specially designed and constructed near Osservatorio Astronomico di Padova (no similar facility was available insofar in our institution). The present status of this optical laboratory is shown in Figure 5. The SARG optical laboratory (approximately 120 m² plus a large storing room) includes a clean room (approximately 20 m², certified class 1,000) constructed by Ferraro Arredi Tecnici; a fully equipped electronic desk; office room (with space for the instrument workstation); and suitable service room required for operation. The laboratory is air-conditioned; a quite strict temperature control in the clean room (at 20±0.5 C) ensures that the instrument will be at operation temperature during alignment even though the instrument enclosure will be open most of the time.

7. REFERENCES

1. Baranne A., 1972 in ESO/CERN *conf. On Auxiliary Instrum. For Large Telescope*, eds. S.Laustsen and A. Reiz, Geneva 227
2. Diego, F., 1994, in *Istrum. In Astron. VIII*, eds. D.L. Crawford and E.R. Craine, SPIE Proc., **2198**, 525
3. Gratton R.G., Bonanno G., Bhatia R., Cavazza A., Claudi R.U., R., Ferretti F., 1996, SPIE Proc., **2871**, 1204