

A Path to the Stars: the Evolution of the Species in the Hunting to the GRBs

Fabrizio Vitali^{*a}, Guido Chincarini^{b,c}, Mario Zannoni^b, Stefano Covino^c, Emilio Molinari^{a,d}, Stefano Benetti^e, Carlotta Bonoli^e, Favio Bortoletto^e, Enrico Cascone^f, Rosario Cosentino^d, Francesco D'Alessio^a, Paolo D'Avanzo^{b,c}, Vincenzo De Caprio^c, Massimo Della Valle^{f,g}, Alberto Fernandez-Soto^h, Dino Fugazza^c, Enrico Giro^e, Demetrio Magrin^e, Giuseppe Malaspina³, Lech Mankiewiczⁱ, Raffaella Margutti^b, Ruben Mazzoleni^c, Luciano Nicastro^j, Alberto Riva^k, Marco Riva^l, Ruben Salvaterra^b, Paolo Spanò^c, Monica Sperandio^c, Mauro Stefanon^m, Gino Tostiⁿ, Vincenzo Testa^a

^aIstituto Nazionale di Astrofisica - Osservatorio Astronomico di Roma, Via Frascati, 33, 00040 – Monte Porzio Catone (Roma), Italy

^bUniversita` degli Studi di Milano – Bicocca, Dipartimento di Fisica G. Occhialini, Piazza della Scienza 3, 20126 Milano, Italy

^cIstituto Nazionale di Astrofisica - Osservatorio Astronomico di Brera, via Bianchi 46, 23807 Merate (LC), Italy

^dIstituto Nazionale di Astrofisica - Telescopio Nazionale Galileo, Rambla José Ana Fernández Pérez, 7, 38712 Breña Baja, TF – Spain

^eIstituto Nazionale di Astrofisica - Osservatorio Astronomico di Padova, Vicolo dell'Osservatorio, 5, 35122 – Padova, Italy

^fIstituto Nazionale di Astrofisica - Osservatorio Astronomico di Capodimonte, Salita Moiariello, 16, 80131 – Napoli, Italy

^gInternational Centre for Relativistic Astrophysics, Piazza della Repubblica, 10, 65122 Pescara, Italy

^hInstituto de Fisica de Cantabria (CSIC-UC) - Edificio Juan Jorda, Av. de los Castros s/n, E-39005-Santander-SPAIN

ⁱCenter for Theoretical Physics of Polish Academy of Science, Al. Lotnikow 32/46, 02-668 Warsaw, Poland.

^jIstituto Nazionale di Astrofisica - IASF Bologna, via Gobetti 101, 40129 Bologna, Italy

^kIstituto Nazionale di Astrofisica - Osservatorio Astronomico di Torino, Via Osservatorio, 20, 10025 Pino Torinese TO, Italy

^lPolitecnico Milano, Dipartimento Ingegneria Aerospaziale, Via La Masa, 34, 20156, Milano, Italy

^mObservatori Astronòmic de la Universitat de Valencia - Calle Catedrático Agustín Escardino Benlloch, 7 46980 Paterna, València - Spain

ⁿUniversità degli Studi di Perugia, Facoltà di Scienze MM. FF. NN., Dipartimento di Fisica, via A. Pascoli, 06123 Perugia, Italy

ABSTRACT

During the last years, a number of telescopes and instruments have been dedicated to the follow-up of GRBs: recent studies of the prompt emission (see for instance GRB080319B) and of their afterglows, evidenced a series of phenomena that do not fit very well within the standard fireball model. In those cases, optical observations were fundamental to distinguish among different emission mechanisms and models. In particular, simultaneous observation in various optical filters became essential to understand the physics, and we discovered the need to have a detailed high time resolution

* fabrizio.vitali@oa-roma.inaf.it; phone +39 06 94286462; fax +39 06 9447243

follow up. Finally, recent observations of the polarization in GRB 090102 clearly indicate the presence of an ordered magnetic field favoring the electromagnetic outflows models. This is, however, only one case and, in order to detail properly the model, we need a bit of statistics. But, after the Swift launch, the average observed intensity of GRB afterglows showed to be lower than thought before. Robotic telescopes, as demonstrated by REM, ROTSE, TAROT, etc. (but see also the GROND set up) is clearly the winning strategy. Indeed, as we will also briefly discuss later on, the understanding of the prompt emission mechanism depends on the observations covering the first few hundreds seconds since the beginning of the event with high temporal resolution. To tackle these problems and track down a realistic model, we started the conceptual design and phase A study of a 4 meter class, fast-pointing telescope (40 *sec* on target), equipped with multichannel imagers, from Visible to Near Infrared (Codevisir/Pathos). In the study we explored all the different parts of the project, from the telescope to the instrumental suite to data managing and analysis, to the dome and site issue. Contacts with industry have been fruitful in understanding the actual feasibility of building such a complex machine and no show stoppers have been identified, even if some critical points should be better addressed in the Phase B study. In this paper, we present the main results of the feasibility study we performed.

Keywords: GRB follow-up, telescope, fast pointing, focal plane instrumentation, high temporal resolution, simultaneous multichannel photometry, spectroscopy, polarimetry.

1. INTRODUCTION

Since the discovery of a dynamic Universe on time scales of hours and seconds, it became of paramount importance to have a high sampling frequency of the data (seconds to tens of seconds). To some extent, a new epoch started in the late fifties, early sixties with the discovery of short periods in cataclysmic variables (U Geminorum, DQ Herculis, AE Aquarii, etc). As shown by the observations in the X and gamma ray, accretion on neutron stars and black holes generate also signals of very short duration, milliseconds and some time even less. These bursts of light make it mandatory to have fast response detectors and fast moving telescopes to detect the event during their birth and subsequent rapid evolution: astronomers need large apertures and very efficient instruments to detect the faintest signals and large and efficient telescopes reacting immediately to any alert. In 2003, in the frame of the Swift project, our group designed, realized and managed the 60 *cm* robotic visible-infrared telescope REM [1], installed in the La Silla mountain, hosted by the ESO facility. At that time, the main goals were, applying the same strategy used in Swift, to respond fast and automatically to the BAT alert and to complement Swift in the Near Infrared (NIR), to better cover the whole range of wavelengths (useful to the GRB physics) and having in mind to also have the capability to detect high *z* bright objects. But the real need of something new became apparent with the studies of various GRBs. It became clear during the years that a full understanding of the emission mechanism needed high temporal resolution optical observations during the prompt emission and soon after. In other words we needed a large light bucket and a good detector.

Thanks to funds received by the Italian Research Ministry, Istituto Nazionale di Astrofisica and Università degli Studi di Milano-Bicocca, we carried out a feasibility study to build and operate a robotic 4*m* class telescope, equipped with VIS and NIR instruments, able to react to a satellite trigger in less than 50 *sec* (with a goal of 30 *sec*): CODEVISIR (Conceptual Design for a VISible and nIR telescope).

This new instrument will be able to collect simultaneous images in the visible *g*, *r*, *i*, *z* and NIR *J*, *H* and *K* filters. The main tasks of the telescope would be primarily the follow up of GRB (but also for SNe and selected ToO) to record the early ($t-t_0 < 50$ *s*) phase light curve with high temporal resolution and simultaneous multiband imaging, to allow the derivation of the GRB spectral energy distributions and Photo-*z*, even for high redshift GRBs: as the naked eye GRB 080319B has shown [3], micro-variability (sub *sec* time-scale) during afterglow prompt can be a powerful diagnostic tools of the physical conditions in the emitting region. Moreover, spectroscopy and polarimetry should be performed for the more brilliant GRBs. Of course, in addition to this primary task, other complementary could be implemented: when not observing GRBs, the telescope will be devoted to ancillary science programs, spanning from Supernovae to X-Ray Binaries, from Active Galactic Nuclei to Stellar Evolution and Star Formation. The large experience we gained in the design, construction, operation and data handling of the REM telescope make us a skilled and trained team to carry out the job. We present here a summary of the result of our feasibility study, that can be found in detail in [2].

2. THE SCIENCE BEYOND PATHOS

During the last two decades, the development of our astronomical knowledge has been impressive thanks to a tremendous improvement of the technology and led to tackle the big themes of Cosmology and degenerated relativistic objects, Neutron stars and Black Holes, in a very systematic and precise observational and theoretical approach. This led to new understanding, new ideas and guidelines for the future.

The main themes in Cosmology have been discussed in documents like the US Dark Energy Task Force and ESA-ESO Working group on Fundamental Cosmology. It is impressive that in the next few years, more likely during the next decade, we may be able to witness, via weak lensing, more accurate observations of the baryonic acoustic oscillations and of Ia SNe (JDEM/EUCLID); we could unravel the fundamentals of Dark Matter and Dark Energy and finally understand whether or not our current understanding of gravity needs to be changed.

Equally puzzling and fundamental is the understanding of condensed matter, black holes especially, and their role in connection with the evolution of the Universe. The mass distribution of black holes in the Universe seems to be bimodal [3] [4] and spans masses from a few solar masses to masses of the order of 10^8 - $10^9 M_{\odot}$. Most recently it has been discovered that the mass of the central black hole in galaxies correlates tightly with the mass of the host galaxy and consequently both entities participate to the downsizing phenomenon, a term introduced by Cowie et al. [5] to evidence the fact that actively star forming galaxies at low redshift have smaller masses than actively star forming galaxies at $z \sim 1$. The understanding of the details of the physical phenomenon, the process of formation and the cosmic distribution branches in all sectors of our knowledge including stellar evolution, collapse of massive stars and mechanism of emission that seems to involve the whole electromagnetic spectrum and extend to neutrinos and gravitational wave physics.

To cope with such flourishing of ideas, knowledge and data, huge machinery, instruments and surveys, have been set up and planned to collect and analyze relevant data both from space and from the ground.

However, neither the Universe nor its components are static objects. On the contrary the physics related to the collapse of massive stars, merging of NS+NS or BH+NS relativistic objects and accretion phenomena reflect highly variable rapid phenomena manifesting themselves all over the electromagnetic spectrum and involving often the emission of neutrinos and gravitational waves. Indeed it is not very clear yet how these objects form and the sequence of events. The view of a tranquil Universe, indeed, has been shattered since the years when the radio observations and later X-ray data showed the existence of a violent Universe.

It is also well known that different pass-bands of the electromagnetic spectrum carry information about completely different phenomena and eventually completely different locations in space for the same cosmic event: gravitational waves and neutrinos emissions are related to the physics where Newton's description fails and where motions of huge curvatures and huge masses are involved. Nevertheless, the case of long and short GRBs and SNe, clearly show that, in conjunction with theoretical modeling, the phenomena observed at optical wavelengths and X ray must be likely accompanied, and may be preceded, by the emission of gravitational waves and neutrinos. The sequence of events must be tracked down observationally. Gravitational waves and neutrinos detectors of the new generation (LIGO, VIRGO and ICE CUBE) will likely revolutionize our understanding of the Universe and perhaps of physics.

In the case of Gamma Ray Bursts, most of the information related to the detailed emission mechanism and central engine, which nature is still completely unknown, is contained in the very first few minutes of the event. Indeed, early multi-wavelength time-resolved observations are the only way to a deep understanding. This applies not only to the observations and studies of GRBs but also to most of the phenomena related to relativistic objects, BHs and SMBHs, fields of astrophysics that are heavily observation driven. We need to see the formation of a BH (or NS) in real time. To this aim the technology must open to a new technological endeavor. The goals are early and autonomous detection at optical wavelengths, coordination with other detectors, GW and neutrinos especially, and "no telescope points faster" and this would cause the development of new technology and needed knowhow. With these means we will have the possibility to be ahead in giving a sensible contribution [identification, follow up and models] to the solution of fundamental physical problems, like the details on the collapse of very massive stars that involves the observations of SNe and GRBs. The state of the art in science and instrumentation will be clear from the discussion below.

A telescope large enough to follow up fairly faint objects with high time resolution and tens of seconds after alert (GW detectors, neutrinos detectors or high energy and optical wide field searchers) may allow witnessing the event in real time since the very beginning.

Besides the main goals described above, many other important scientific results may be achieved with the facility here proposed, such as Detection of GRBs at very high redshift, Polarimetry of GRB prompt emission and afterglow, AGN/Blasar science, Supernovae, Gamma- and X-ray binaries, Young stellar objects.

3. THE TELESCOPE CHALLENGE

The above mentioned science cases drive the design of the Pathos telescope. Our feasibility study is then based upon the following main requirements:

- The collecting area shall be equivalent to one telescope with a primary mirror of 3-4 *m* in diameter;
- The pointing in any position of the sky shall be rapid; required average speed is 60°/50 *s* (goal 60°/30 *s*); after that time the telescope shall be accurately positioned (few *arcsec* RMS) and stabilized (tracking with a fraction of *arcsec*).

In order to have a fast pointing telescope, the optical scheme of the telescope, the mechanical configuration and the location of the instrumental focal plane are worth to be taken in consideration, to minimize momenta of inertia and unbalancing.

The study of the feasibility of a 3*m* class telescope fulfilling the previous requirement has started with the investigation of different and alternative possible solutions. On the base of these evaluations and of the first replies from industry, it has been decided to adopt for the baseline design of the PATHOS telescope on an alt-azimuth mount in the Cassegrain configuration (Ritchey-Chretien) with the instruments at the Cassegrain focus.

Optical Layout

The main Optical Requirements for the telescope are:

- Primary mirror clear aperture: 3 *m*;
- Configuration Ritchey – Chrétien with Cassegrain focus
- Primary focal ratio max *f*/1.8 (goal is *f*/1.5)
- Effective focal ratio *f*/10
- Scale: 145 $\mu\text{m}/\text{arcsec}$ or 6.9 *arcsec/mm*;
- Operational waveband 400 *nm* to 2500 *nm*
- Minimum Corrected Field of View (FOV): 15 *arcmin* (circular)
- Surface quality: Wavefront error of M1 and M2 better than $\lambda/6$ PtV ($\lambda=632.8$ *nm*).
- All telescope mirrors must be coated with high reflecting protected material (R>88%).

The Ritchey-Chretien optical layout has been chosen for its compactness. In Table 1 the main parameters of the primary and secondary mirrors are reported, and Figure 1 shows the optical layout of PATHOS with the relative spot size diagram at different wavelengths (400 nm, 550 nm, 700 nm, 1 μm , 2.5 μm).

Focus location

A simple model has been made to evaluate the impact of different distribution of masses in the case of the Alt-Az mounting. It has shown that *i*) after the optimization of the design, the moment of inertia of the movable parts with respect to the Elevation and Azimuth axis are between 1.3 and 1.6 lower when instruments are located at the Cassegrain focus than at the Nasmyth focus depending on the elevation angle, *ii*) the variation of the Moment of Inertia with elevation angle is less in the Cassegrain case (1.25 versus 1.48) and *iii*) the total mass itself is more than 10% less in the Cassegrain focus.

Table 1: Optical parameters of the primary and secondary mirrors

Surface	Radius	Thickness	Conic constant	Aspheric departure	Type	Aperture
M1	-9000.000 mm	-3631.5 mm	-1.010762	219 μm	Concave hyperbola	3000 mm
M2	-2043.529 mm	5790.0 mm	-1.921249	56 μm	Convex hyperbola	600 mm
Focal plane	-925	-	-	-	-	130 mm

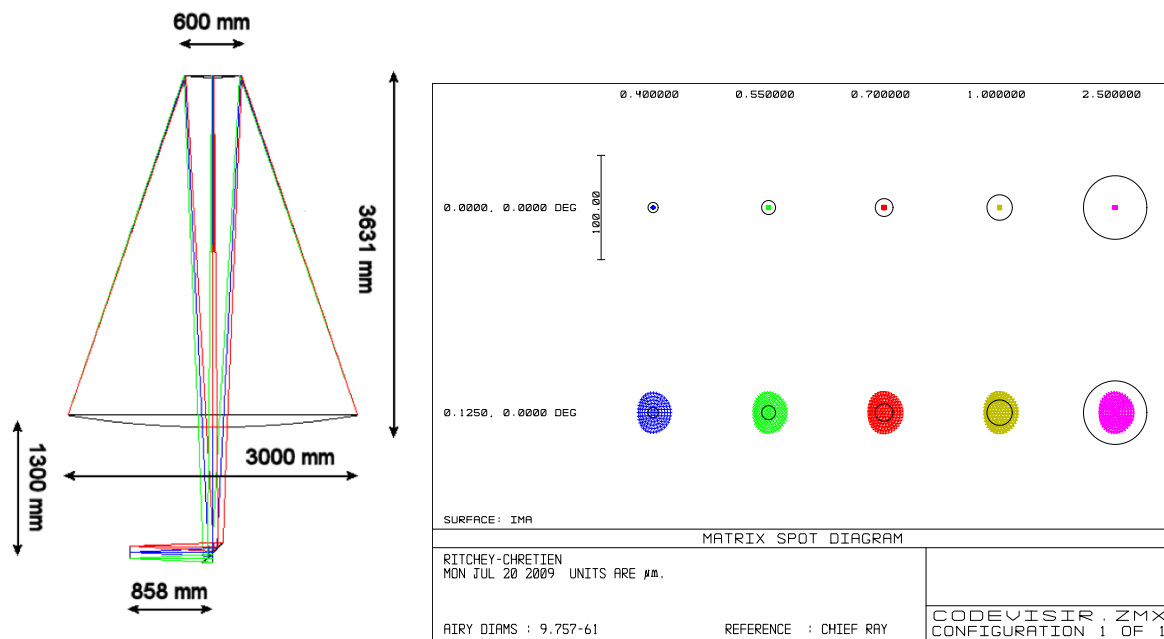

Figure 1: The optical scheme of the telescope and the spot diagram at different wavelengths.

3.1 Mechanics

Since the beginning of the project it was clear that the involvement of the industry was necessary for its success. On the base of the replies from the industry, it has been possible to define an extended set of (likely reasonable) requirements for the full mechanical system [6].

- Mounting Alt-Azimuth;
- Elevation range: $-90^{\circ}.0$ to $90^{\circ}.0$, excluding the zenith blind spot. In case of fast pointing, the derotator can be disabled to allow the cross of the zenith;
- Zenith blind spot no larger than 2 deg around zenith (TBC);

- Pointing rapidity: $60^\circ/50\text{ s}$ (goal $60^\circ/30\text{ s}$);
- Pointing Accuracy: 2-3 *arcsec RMS* over the full sky after implementation and calibration of the Pointing Model;

Tracking error:

- 0.2 *arcsec/10 min* without autoguider;
- < 0.1 *arcsec RMS* for 1 *hour* with autoguider / slit viewer;
- Movements Ranges: Azimuth: $\pm 270^\circ$ (goal $\pm 360^\circ$), Alt: $\pm 90^\circ$, Derotator: $0^\circ - 360^\circ$.

Derotator / Instruments requirements:

- Field derotator must be foreseen to provide the unguided rotation tracking accuracy.
- Total instrument mass: 1200 *kg*
- Allocated space for instrumentation: A cylindrical volume of 3 *m* in diameter and 375 *mm* below the derotator flange.
- Cables: TBD
- Power consumption: TBD

A conceptual mechanical layout of the PATHOS telescope is sketched in Figure 2. The design is based on a preliminary rough model proposed by ASTELCO.

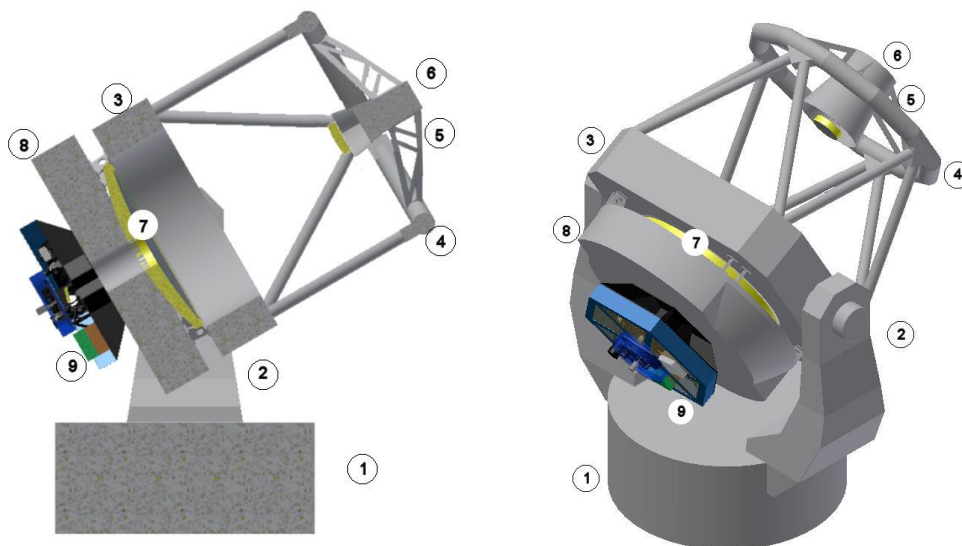

Figure 2: Overview of PATHOS telescope with the instrumentations

The telescope is composed of a fixed basement (1) connected to the pier which is the base for the azimuth movement, a rotating fork (2) which supports the altitude bearings and the drive system, a “tube”, with a centerpiece consisting of a welded box (3) and a tubular structure which supports the upper ring (4), the spiders (5) which hold the M2 cell (6), the M1 cell (7) with the primary mirror and its active supports, an adapter rotator attached to M1 cells (8) that holds the instruments (9).

4. THE INSTRUMENTAL SUITE

4.1 The instrumental configuration

The current configuration of the instrumentation suite for PATHOS has been derived from the scientific drivers, that outlined the needs for a simultaneous coverage of the Visible and Near Infrared bands, from 400 *nm* to 2.5 μm , with a

Field of View of about 10 arcmin^2 , with a very fast response capability and high temporal resolution, of the order of 0.1 sec. Spectrometric and photopolarimetric observations will be needed as well, at least for the most luminous transients.

PATHOS will be equipped with an instrumentation suite able to cover the wavelength range from the Visible (VIS, 400 nm-900 nm) to the Near Infrared (NIR, 1.00 – 2.5 μm) during the same exposure. This will be allowed by a multichannel imaging GROND-like configuration [7] that envisages a detector for each photometric band, delivered through a dichroic cascade along the optical path. The availability of large format arrays, both in the visible and in the infrared wavelength range allows a large flexibility in the optical design that will ensure a Corrected Field of View of about 10 arcmin for both channels.

Two ancillary instruments will complete the instrumentation suite, a visible spectrograph and a photopolarimeter, fed by rotating the M3 mirror.

The instrument set up has been thought by integrating optical and mechanical requirements. The mechanical design will be driven mainly by four main requirements:

- extreme light weighting of the structure (the fast pointing nature of the telescope);
- weight distribution (same reason as above);
- automation requirement;
- reliability.

The light weighting is the predominant aspect that has been investigated, both for reducing the overall mass (centrifugal and earthquake passive induced accelerations) and for reducing the thermal inertia of the overall system.

During the conceptual study, different configurations in terms of main structure and subsystem locations have been analyzed to optimize weight and balancing. The overall weight obtained from a 1st order dimensioning of this type of structure, in aluminum, is about 715 Kg (see Figure 3-right). This instrument set up has the evident advantage of the high accessibility to all subsystems and in addition the room behind M3 is let free and can be used for possible future add-ons. The possible gain deriving from the use of advanced materials like Carbon Fiber Reinforced Panels has been also investigated, with gain in terms of overall weight up to 20%.

The telescope will be remotely managed, meaning that all the possible failures must be avoided via proper solutions/redundancy. This implies also an optimization of the maintainability items like handling, accessibility, minimizing of servo-systems, because the absence of the dedicated personnel impose high repairing costs.

The instruments carousel will be organized into 3 systems:

- Multi Color Camera (MCC), VIS camera (g,r,i and z bands, 0.4-0.9 μm) plus NIR camera (J, H and K, 1.0-2.4 μm);
- Spectrograph (SPEC), 0.4-0.9 μm ;
- Fast PhotoPolarimeter (FPP), 0.4-0.9 μm ;

The MCC will be continuously fed by the telescope beam (see Figure 3-left), whereas SPEC and FPP will be selected by properly moving the M3 mirror.

The main idea that is driving the MCC is the simultaneous acquisition. This can be done by considering a single detector for each band (g, r, i, z, J, H and K, see below for a more detailed description). The infrared part of the instrument will be hosted in a cryogenic environment, to avoid the thermal background and to minimize the level of the detectors dark current.

4.2 The Main Scientific Instrument: the Multiple Color Camera.

To allow a simultaneous observation of the scientific target, the MCC configuration will envisage four visible arms, covering the Sloan g,r,i and z bands, and three near infrared arms for the J, H and K bands, simultaneously imaged through a dichroics cascade, as shown in Figure 4-left. The lens coating, the dichroics and the filters have to ensure the best overall efficiency, then particular care should be taken in the response curve definition and in the prototyping of the most challenging part, as the two main and larger dichroics. We made a market survey and found several optics firms

able to deliver high quality dichroics and filters, up to 98% for the dichroics (as shown in Figure 4-right for the Laser Zentrum Hannover dichroic, the same provider of GROND) and more than 90% for the filters.

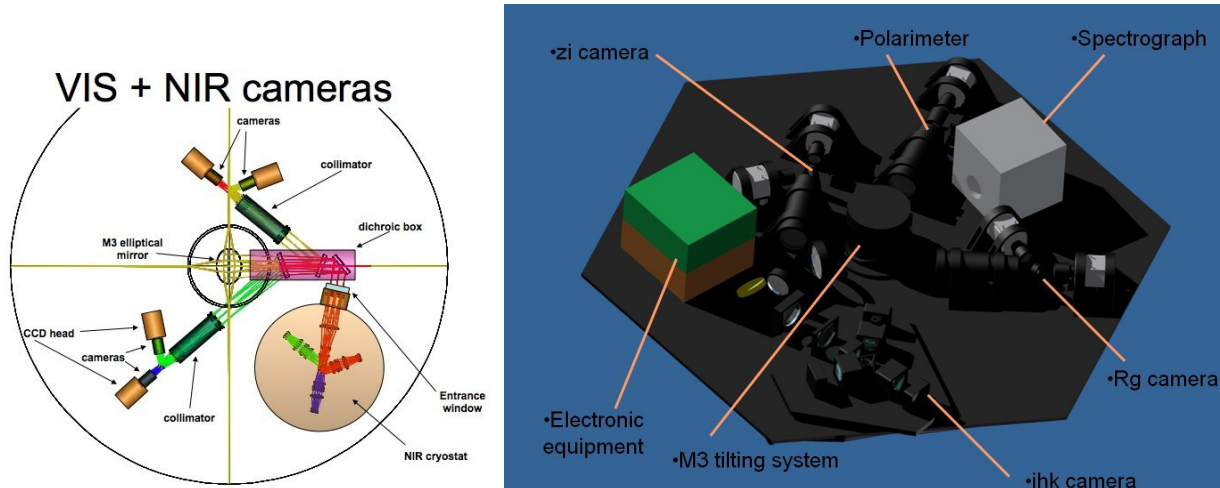

Figure 3: The optical (left) and mechanical (right) scheme of the PATHOS focal plane with the VIS and NIR cameras.

The MCC will be directly linked to an optical bench at the rear of the telescope, to ensure stiffness and alignment during the telescope movements. The configuration of the different parts of the instrument should be optimized also to ensure the best access to the instrumentation for maintenance.

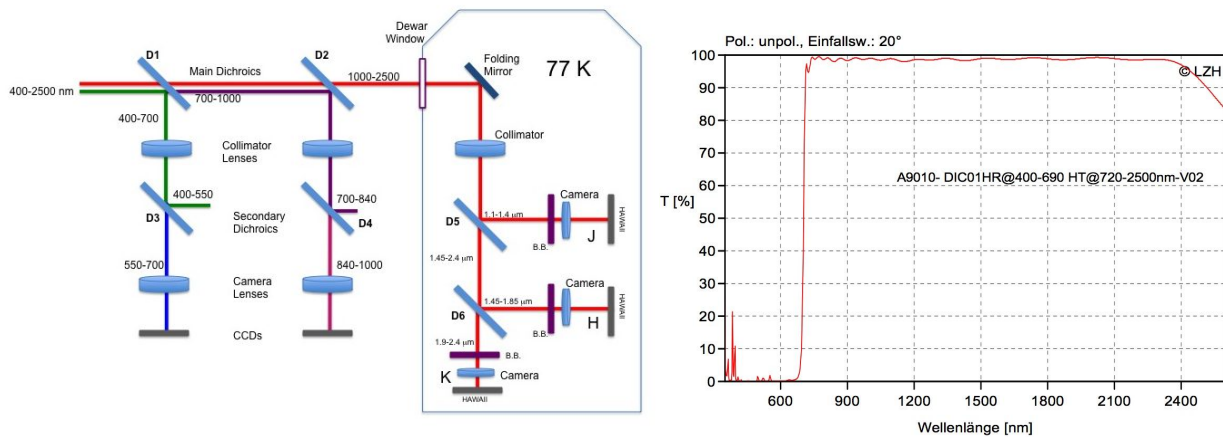

Figure 4: The dichroics cascade feeding the VIS and NIR cameras (left) and an Example of dichroic transmission curve in the range 400-2500 nm (right, from LZH).

The Visible Arm

The VIS cameras will be devoted to the simultaneous observation of the same field of view in four different bands. At least three different dichroics are needed to split wavelengths. They can be put both at a convergent (or divergent) beam, and in a collimated beam. Field of view and pixel scale requirements ask for focal reducer system. The large field of view cannot be achieved through classical corrector lenses just in front of the telescope focal plane, so a collimator-

camera system is the only choice. Then, some of the dichroics can be put within the focal reducer elements in order to reduce their size and complexity, gaining in space envelope for the overall instrument suite at the same time. So, according to Figure 4-left, we chose to put a dichroic (D1) in the convergent beam coming from the telescope secondary mirror, and making the second wavelength split in collimated beam (D3 and D4) (see also Figure 5-left). The other large dichroic D2 is used to split VIS and NIR light, feeding the NIR cameras. The minimum pixel scale to give good seeing sampling should be larger than 3 pixel/arcsec. To cover a 10x10 arcmin onto a 2Kx2K CCD detector area, the best compromise can be reached with a 3.4 pixel/arcsec plate scale. Because the telescope focal ratio is about F/10, a F/10-F/3.5 focal reducer is needed. A lens class solution will give the best performances in term of efficiency, cost and image quality, within a limited space envelope, in order to cope with many arms within the same optical bench assembly. A possible optical design has been done, meeting all those requirements. All lenses but two of them are spherical, to keep low costs. Maximum diameter is 150 mm. The layout in Figure 5-left shows one arm of the two (zi and rg) VIS cameras. Dichroics and filters will be placed near the image pupil of the telescope (in the middle). All the optical train is 70 cm long, and the collimated beam have a 40 mm diameter. This same design will perform very well over a wide wavelength range (330-950 nm). This means that multiple arms can be built with just two identical collimators and four identical cameras, greatly reducing costs and alignment efforts. The VIS camera image quality can be estimated from spot diagrams in Figure 5-right, where more than 80% of the energy is within 1 arcsec everywhere.

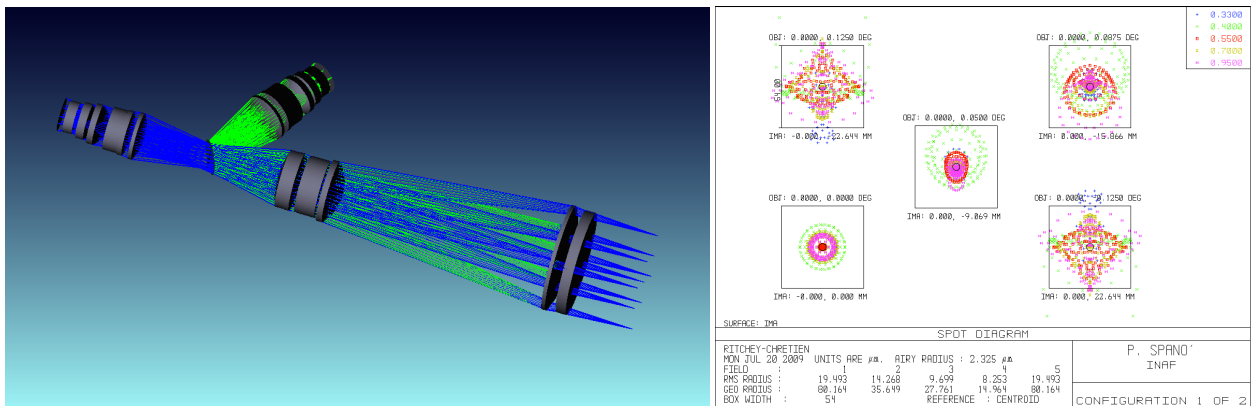

Figure 5: The basic optical scheme for one the VIS camera arm and the relative polychromatic spot diagrams. Boxes are 1x1 arcsec wide.

Main instrument mechanics is designed following a modular implementation (see Figure 6): the two visible collimators (zi and rg) are identical and the optomechanics is very simple due to the fact that a simple barrel could handle all the foreseen lenses. The estimated weight for each collimator assembly is about 15-20 Kg. All the cameras are identical and implement a focusing system which will move the proper lenses with respect to the CCD assembly mainly for thermal defocusing correction. The foreseen weight for each camera assembly is about 13-17 Kg.

The Detectors and Electronics

The VIS image detection system is based on a set of four CCD cameras with 2Kx2K class detectors. Due to the relatively high background present in the VIS observations (broad-band imaging), the use of autonomous thermoelectrically cooled cameras seems to be the most appropriate solution. With such a choice we will avoid the insertion of more complicated cooling systems (liquid nitrogen or cryocoolers) in favor of a simple water recycling system. There is presently an extremely wide market for commercial cameras mounting customized scientific detectors and operating in cooled mode inside a windowed thermally insulated chamber. Even overall dimensions and resulting weight is reduced when compared to classical cryostat based cameras serviced by modular control electronics. Maximum of compactness and system efficiency, even in terms of spare parts, will be obtained using exactly the same camera model to populate VIS allowing diversification only for the detector QE specifics in the four bands.

The present reference choice is among two quite similar thermoelectrically cooled cameras, the Princeton Pixis2048 and Andor iKon-L 936, both allowing the insertion of 2Kx2K CCD detectors (all the standard E2V scientific set with different coating and substrate options is available on demand) with cooling capabilities below -60 °C and with the

possibility to increase cooling with a closed circuit liquid coolant. Insertion on the informatics network taking care of detectors is simplified by the availability of fiber-based USB interfaces for both considered cameras.

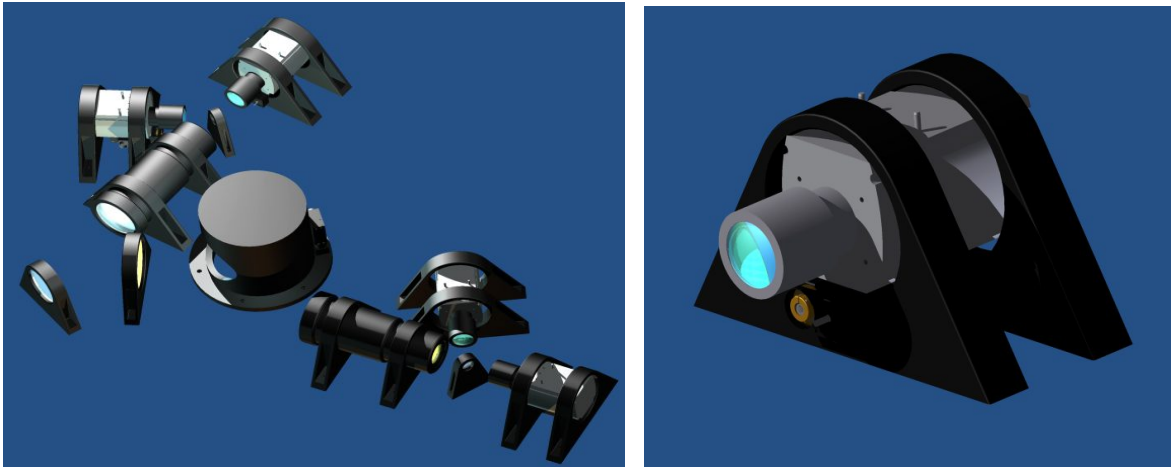

Figure 6: Vis arms (r,g,z,i) and tilting M3 mirror (*left*) and a detail of the camera assembly (*right*)

The NIR Arm

Following the same ideas developed for the VIS channels, NIR wavelengths are split via two dichroics placed into a collimated beam (see Figure 7). A NIR optimized collimator camera system will match the telescope focal ratio to the NIR detector pixel size. Special infrared glasses will be used to optimize both transmission and image quality. No cemented optics is foreseen to avoid damages during cooling down. Image quality is almost diffraction-limited over the whole field of view.

First collimator lens can be used also as cryostat window, reducing the number of air-glass interfaces. In this case, first collimator window will be warm, while all following components will be cooled to 77 K to reduce thermal background, especially in the K band. Also dichroics will be optimized to work at low temperatures. To better define spectral bands (JHK), also multilayer filters will be used. A camera prototype will be set up to understand if we need a cryogenic focusing system onto each channel, to improve image quality. This can be possibly realized with a moving lens into the camera assembly, or at the detector level. The K-band channel will suffer from thermal emission, and then a dithering system will be added, to reduce this effect. A possible solution is to add a folding mirror into the camera assembly that can be moved with cryo motors.

The standard filters for NIR astronomy are designed to fit in the atmospheric windows. If needed, a non-standard filter centered at about $1 \mu\text{m}$ can be possibly added, as in the case of REMIR [8].

The NIR arm needs a cryogenic environment, this implies to foresee a dewar with proper shielding and insulation. The JHK arms have a common collimator and three separated but identical cameras. The first lens of the collimator will act as dewar window, and just behind it a shutter for calibration purposes will be installed. The baseline optomechanical mounting is a classical V Shaped support with clamping springs. All the elements will be fixed to a unique bench which will be mounted through proper flexural blades in order to have a kinematic mounting which allow thermal contraction between the cold bench and the dewar.

Differently from visible CCD detectors, where only the internally generated dark current must be limited by active cooling, IR detectors working beyond $1\text{-}2 \mu\text{m}$ are sensitive also to the possible thermal background generated by surrounding surfaces. A limitation to this effect requires the insertion of actively cooled shielding surfaces.

In the past years, great experience has been achieved in the cryogenics field and, in particular in the astronomy field, where this kind of technology is now standard. Standard solutions exist allowing cooling down and keeping astronomical

instruments cold for a long time, with high thermal stability and reliability. These solutions include cryocoolers formed by a main compressor linked through a high pressure He line to a smaller cold head that provide the cryogenic temperature heat sink to the instrument. These cryocoolers can easily exceed cryogenic power of tens of Watts @ 77 K (for near infrared instruments). These have been extensively used at the focal plane of telescopes and definitively provided a stable and reliable system.

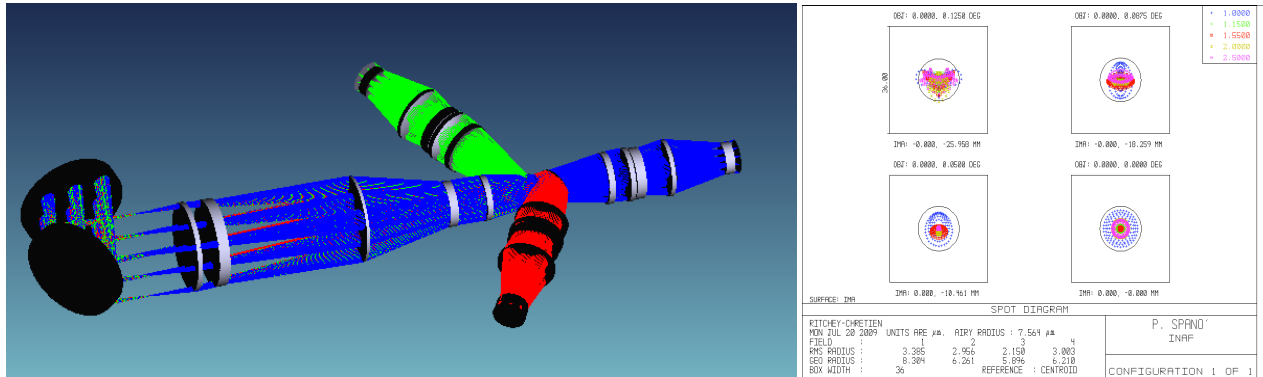

Figure 7: The optical (left) and polychromatic spot diagrams (right) for the NIR camera.

Our current design is based on the Leybold CoolPower 5/100T Cryocooler, a Dual Stage Cold Head that can provide up to 100 W @ 80 K at the 1st stage and 35 W @ 40 K at the 2nd stage. The basic scheme of the cryostat envisages an optical bench on which all the opto-mechanical elements and the NIR arrays rely, surrounded by two radiation shields to avoid the direct irradiation from the external blackbody at ~300 K. As usual, a set of standard devices will be hosted in the cryostat, as a Lyot stop (to shield the thermal diffuse light), temperature sensors (to monitor the temperature of the most critical points of the cryostat, like the arrays and the optics), charcoal getters (with their own heaters), heaters (to fine tune the bench temperature), a dithering mirror and a movable shutter (to perform dark current measurements).

One main constraint is given by the bending radius of the hoses which bring the cooling fluid (Helium) to the instruments, which is 25 cm. A possible solution for the transportation of these hoses is the use of rotating joints, which have been already installed and have demonstrated high reliability in other instruments (NICS @ TNG).

The Detectors and Electronics

At the time of writing, the best NIR detectors available for the astronomy market are from Teledyne and Raytheon companies, being the former better in terms of noise. Anyway, the rapidly evolving technology in the field of NIR detector suggests to be careful in the choice of the final detector and to follow all the evolution of the market in this field. Currently, we are oriented towards the Teledyne Hawaii-RG detector series, that can be delivered in different format (1kx1k, 2kx2k and even 4kx4k pixels) and different wavelength coverage (cut-off at 2.5, 1.7 and 5.3 μm are standard). The array with cut-off at 1.7 μm, thank to the substrate removal, presents higher quantum efficiency with respect to the standard array. This opportunity for the Teledyne arrays allows certain flexibility in the choice of the best detector for each photometric band.

The Teledyne detectors show the better performances in terms of dark current (<0.01 e-/s/pixel @ 90 K, for a 2.5 μm cut-off wavelength), Read Out Noise (13-15 e- with Single CDS, down to < 3e- with multiple-sampling) and Quantum Efficiency (>80 %) [9] with respect to the Raytheon products. Moreover, Teledyne provides the SIDECAR™ ASIC controller. This is a new concept of IR array controller characterized by a high level of integration, capable to integrate in the same chip the standard function to control the array (input commands, phases generator, signal pre-amplification, DAC conversion) and built to be extremely flexible in term of code generation to fit with special applications.

4.3 Ancillary Instruments

Two ancillary instruments are envisaged to equip the focal plane of Pathos, feeded by the M3 rotating mirror a Spectrograph and a Fast Photometer & Polarimeter.

In Figure 8-left the opto-mechanical layout of the spectrograph is shown. The spectrograph size is relatively small (longest dimension ~30 cm) and the only movable part is the grating, mounted onto a rotating stage, to tune the central

wavelength. A slit of 1 *arcsec* will provide a spectral resolution of 800 ($\lambda/\Delta\lambda$) given by a standard 600 *l/mm* reflection grating. The height of the slit is 4 *arcmin*, so long-slit observations are feasible. The simultaneous spectral coverage is about 200 *nm*, and the full coverage from 370 to 900 *nm* can be done in three exposures. The detector area is 1Kx1K, with a pixel size of 13.5 μm . The efficiency of the system is very high, 45% peak, including the losses at the disperser level.

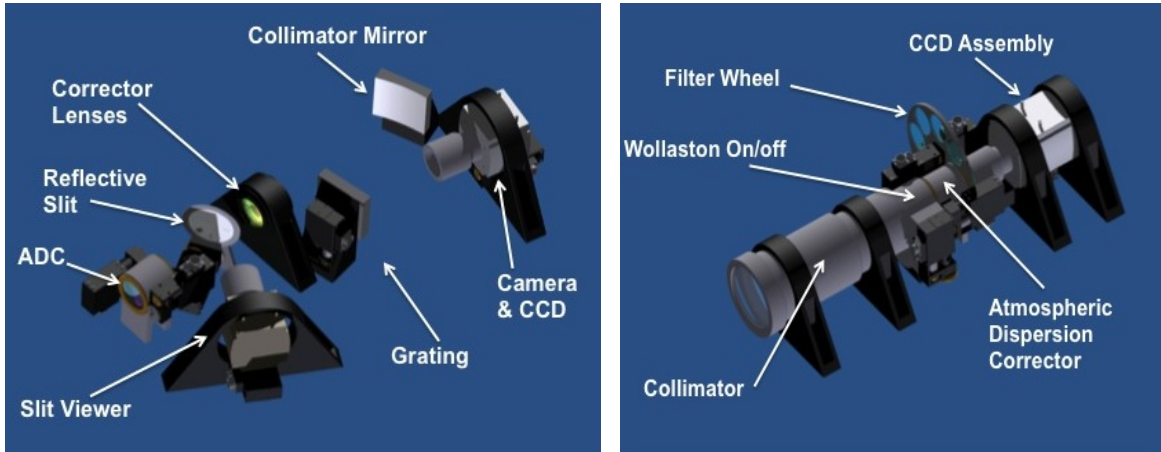

Figure 8: the opto-mechanical layout of the spectrograph (*left*) and of the Polarimeter (*right*).

The polarimeter opto-mechanical layout is shown in Figure 8-*right*. The optical design and spot diagrams are the same as the ones of the NIR arm, with a field around 4x4 *arcmin* and a wavelength coverage between 400 and 800 *nm*. The incoming beam is collimated through lenses and then split into four beams, each one containing the information of one of the Stokes parameters, through a combination of Wollaston prisms. This combination takes the name of WeDoWo (WEdged DOuble WOLLaston) [10]. Each beam is then focused onto the detector. The main possibility is to drive all the four beams into the same detector. Deeper study arises from the filtering option, where the possibility to cover all the visible spectrum and part of the very near infrared becomes interesting. A filter wheel will be placed in the parallel beam, with at least three positions (standard UVB filters) and an empty slot for white-light observation mode.

5. CONTROL SW, DATA MANAGEMENT AND ANALYSIS

The development of the control software and Data Management System (DMS) will greatly benefit from the experience gained with REM [11]; however it will be specifically designed to optimize the various tasks of this unique telescope. The operations of the whole system will be managed by a set of processes, each one dedicated to a very specific task and in constant inter-communication. A dedicated process will then act as a coordinator of all the above activities.

However, with respect to the REM DMS, some components will be completely re-designed in order to satisfy the higher requirements of the project in terms of: (1) safety, (2) reliability, (3) effectiveness. In particular the huge amount of data (scientific and calibration frames, telescope and instruments telemetry, meteo, etc.) will require the DMS to make use of: i) reliable internal and external communication network, ii) reliable redundant sub-systems, iii) fast and flexible relational database system, and iv) multithread processes with a client/server architecture.

The two core components are the “Observing System” at the telescope site and the “Supervisor System” at a remote site in Italy. The various components will communicate mainly through TCP/IP sockets with processes implementing a client/server scheme. The Observing System will save all the data in a local DB system and will perform all the low-level data reduction.

Data will then be transferred to Italy (in a synchronous or delayed manner) where all the high-level processing will be performed. The general users will have access to the data stored in the latter DB server through an internet accessible server using several types of interfaces ensuring full flexibility. The DB server will be mirrored at least at two sites.

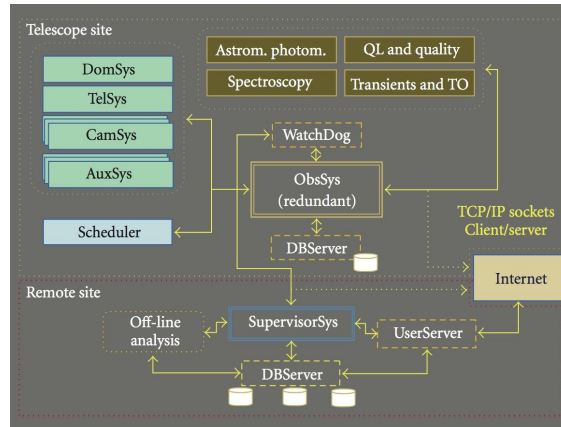

Figure 9: A schematic view of the foreseen control s/w and DMS

This project has been designed with the explicit main goal to manage unexpected alerts from many sources. There is a large family of astrophysical objects potentially providing events occurring on rapid timescales, that is, comparable or shorter than the typical telescope pointing time (about 30 – 60 s) as GRBs, XRBs, high-energy transients of various sort, and so forth. We do not discuss here the astrophysical interest of rapid observations of these objects, however it is the case to remind us that optical and near-infrared observations carried out on the occurrence (or with a delay of a few tens of seconds) of high-energy events with a telescope with large collecting area are a real novelty and will effectively open a new observational window. Dedicated software tools will be implemented to perform real-time image analysis of transient events. The results will then be used to automatically and iteratively modify the observing schedule to efficiently track the event along its evolution.

6. THE WIDE FIELD ARRAY

Pathos will be equipped with the most advanced visible Wide Field Array ever built, capable to trigger the Pathos observations of rapidly variable phenomena (SNe and GRBs), in absence of satellite γ and X-ray triggers for GRBs. The self-triggering capability will be secured by a construction in collaboration with the “Pi of the Sky” group [12] of a dedicated wide-field (WF) array. Here the main challenges are to considerably shorten the time scale with which the sky will be probed, as compared with already existing projects, and to develop a concept of autonomous CCD camera equipped with sufficient computing power, memory and GB-Ethernet link as to serve as independent unit capable of performing at least primary image processing and analysis, discover candidates for optical transients and exchange corresponding information with other such cameras and wide-field arrays present in the network.

The envisaged architecture assumes 2 sites located at a base distance of about 100 km. Each site should be equipped with 16 CCD cameras, covering about 2 sr of the sky. Depending on settings, cameras from both sites will work pair wise in coincidence or observe separate FOV's. Note that for short optical transients, elimination of background due to cosmic radiation requires observation of the same FOV by at least 2 units. In addition, sufficiently long baseline allows eliminating Sun reflections from military, maneuvering satellites with orbital elements which are kept secret to civilian community. In order to filter out background and ultimately to select transients of astrophysical origin in the real time requires development and implementation of very efficient and clever algorithms.

As it has been demonstrated by e.g. GRB080319B, the scientific significance of future GRB observations will depend crucially on ability to increase substantially time resolution into a sub-second domain and decrease image processing time for each frame. EMCCD technology allows for significant increase of gain, reducing the influence of the readout noise even for very fast readout speed. Moreover, embedded processor technology with Linux operating system on board together with a dedicated DSP processor can both simplify communication problems and allow for fast pre-processing like dark frame subtraction and flat fielding within the camera itself. Note that the software itself will aim to high temporal resolution: automatically (and to reduce reading time) the software will be addressed to reading only a small array of pixels centered on the source. A study in this direction resulted in construction of a prototype of an intelligent camera with embedded processor with a Linux system. 2 such cameras have been completed and tested in Warsaw, demonstrating potential of this new solution.

7. DOME AND LOGISTICS

The requirement on the pointing rapidity of the telescope, force us to find a proper solution for the dome, that should follow the velocity of the telescope. Nevertheless, other issues linked to the dome choice have to be taken into evaluation, as feasibility, costs, wind and dust shielding, proper thermalization. Different dome configurations are being taken into consideration (horizontal or vertical slit, boxes, geodesic, fully retractable) and some simulations have been done to evaluate the impact of the incoming wind on the dome. Currently, two possible solutions are under study (see Figure 10): i) the “light” solution, which has been designed to investigate the minimum volume and dimensions required [13] and ii) the “classic” solution which is based on a standard model of dome and has been suggested as baseline by one manufacturer.

The presence of a coating chamber close to the dome will be mandatory to reduce risks due to transportation and the loss of operative time.

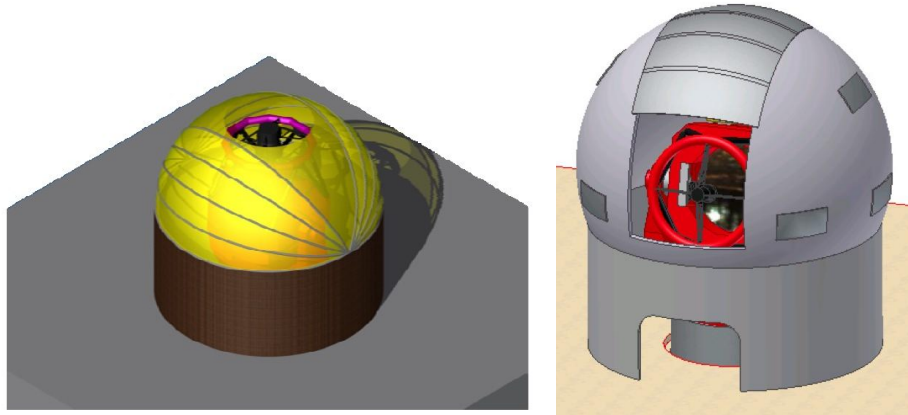

Figure 10: a sketch of the light (left) and classic (right) solution for the dome.

REFERENCES

1. E. Molinari, S. Covino, F. D'Alessio *et al.*, “REM: Automatic for the People”, *Advances in Astronomy*, Volume 2010 (2010), Article ID 253675.
2. F. Vitali, G. Chincarini, M. Zannoni *et al.*, “A Path to the Stars: The Evolution of the Species,” *Advances in Astronomy*, Volume 2010 (2010), Article ID 187269.
3. M. Fukugita & P.J.E. Peebles, 2004, *ApJ*, 616, 643.
4. A. Merloni, 2008, *MmSAI*, Vol. 79, pag. 1310.
5. L. L. Cowie, A. Songaila, E. M. Hu, & J.G. Cohen, 1996, *AJ* 112, 839.
6. M. Riva, F. Bortoletto, C. Bonoli *et al.*, “Mechanical design considerations for a 3m class fast pointing telescope”, 2010, *SPIE this conference*, 7733-29.
7. J. Greiner, W. Bornemann, C. Clemens *et al.*, “GROND—a 7-Channel Imager”, 2008, *PASP*, 120.
8. F. Vitali, F. M. Zerbi, G. Chincarini *et al.*, “The REM-IR camera: high quality near infrared imaging with a small robotic telescope,” in *Instrument Design and Performance for Optical/Infrared Ground-Based Telescopes*, M. Iye and A. F. M. Moorwood, Eds., vol. 4841 of *Proceedings of SPIE*, pp. 627–638, August 2002.
9. J. W. Beletic, R. Blank, D. Gulbransen, *et al.*, “Teledyne imaging sensors: infrared imaging technologies for Astronomy & Civil Space,” in *High Energy, Optical, and Infrared Detectors for Astronomy III*, vol. 7021 of *Proceedings of SPIE*, Marseille, France, June 2008.
10. Oliva, E., 1997, *A&A*, SS **123**, 589.
11. M. Stefanon, S. Covino, D. Fugazza *et al.*, “The REM observing software”, *Advances in Astronomy*, Volume 2010 (2010), Article ID 976890.
12. K. Malek, T. Batsch, H. Czyrkowski *et al.*, ““Pi of the Sky” Detector“, *Advances in Astronomy*, Volume 2010 (2010), Article ID 194946.
13. M. Riva, R. Mazzoleni, “A partially foldable light weighted dome for fast pointing 3m class telescopes”, 2010, *SPIE this conference*, 7733-140.